

## BIS005 オールラウンド

フルカーボン  
+

SHIMANO **105** mix

新価格199,000円税込

マジョーラレッド209,000円税込み

フレーム価格99,000円税込



グロスブラック

		Q7	N	Q1	F	L	H	ST	G	RC	FC	STACK	REACH	WB
430	XS	75.0	500	70.5	45	105	68	430	371	410	570	509	364	968
470	S	74.5	525	72.5	45	120	68	472	371	410	574	530	378	972
490	M	74.5	535	73.0	45	140	68	490	371	410	580	546	384	980
510	L	74.0	550	73.0	45	160	68	510	371	410	590	565	388	990

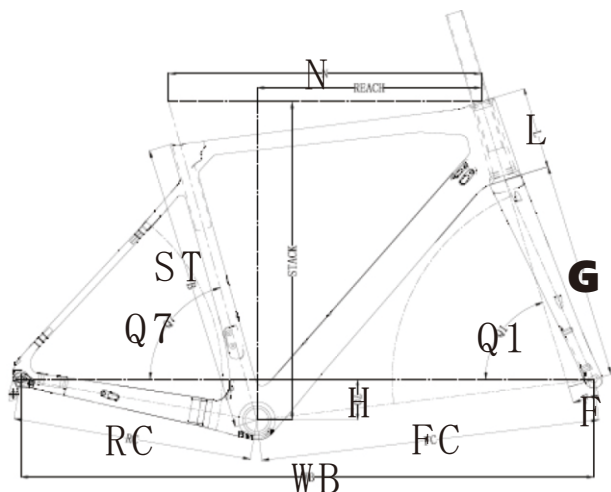

Frame	430/470/490/510 Carbon frame 700*28c
Fork	Carbon fork 700*28c
Handlebar	JH Alloy 31.8mm*XS,S380 / M,L400mm
Stem	JH Alloy 31.8mm XS:70 S:80 M:90 L:100mm
Seat Post	JH Alloy 27.2*350mmL Matte black anodized
Groupset	Shimano 105mix R7000
Derailleur	shimano 105 R7000-SS, 30T MAX
Shift Lever	shimano 105 R7000, 11 speed
Chain	KMC X11
Crankset	Prowheel RPX11-621C-TT-1, 50-34T 170mm
Brake	Tektro, MD-C310, FLAT MOUNT mechanical disk brake, 160mm
Wheelset	XERO BRO-9702-F/R, 700C Alu wheelset
Saddle	Selle Italia X-Base
Headset	NECO, 398/286G BK, 1-1/4" 1-1/8" (28.6mm)
Tire	KENDA, K1018, 700C*25C 410g
thru axle	フロント12mm*100mm*P1.5、リア12mm*142mm*P1.5
Size	XS 430 /S 470 /M 490 /L 510
Weight	9.5kg Ssize



ブルーグレー



マジョーラレッド

